

LM2653EVAL 1.5A Synchronous Switching Regulator Evaluation Board

Introduction

The LM2653 switching regulator provides high efficiency power conversion over a 100:1 load range (1.5A to 15mA). This feature makes the LM2653 an ideal fit in battery-powered applications.

Synchronous rectification and 75 mΩ internal switches provide up to 97% efficiency. At light loads, the LM2653 enters a low power hysteretic or "sleep" mode to keep the efficiency high. In many applications, the efficiency still exceeds 80% at 15 mA load. A shutdown pin is available to disable the LM2653 and reduce the supply current to 7 μA.

The IC contains patented current sensing circuitry for current mode control. This feature eliminates the external current sensing required by other current-mode DC-DC converters.

The IC has a 300kHz fixed frequency internal oscillator. The high oscillator frequency allows the use of extremely small, low profile components.

The evaluation board can be obtained by ordering part number LM2653EVAL from your local National Semiconductor sales office, or National's website at <http://www.national.com>.

Evaluation Board Design

The evaluation board is designed to supply 2.5V at up to 1.5A. The input voltage range is 4V to 14V. Components

National Semiconductor
Application Note 1133
Dongyan Zhou
May 1999



were selected based on the design procedure in the LM2653 datasheet. The feedback resistors can be adjusted to achieve a different output voltage:

$$V_{OUT} = 1.238V \times [1 + (R_1/R_2)]$$

Choose 1% resistors between 10kΩ to 100kΩ for R1 and R2.

PCB layout is critical to reduce noises and ensure specified performance. See the LM2653 datasheet for layout guidelines. The artwork for the evaluation board is shown at the end of this application note.

The schematic for the evaluation board is shown in *Figure 1*, and the parts list is given in *Table 1*.

When the undervoltage protection occurs, the output voltage can be pulled below ground as the inductor current is reversed through the synchronous FET. For applications which need to be protected from a negative voltage, a clamping diode D2 is recommended.

The PGOOD flag goes low whenever the overvoltage or undervoltage latch protection is enabled. The overvoltage protection will be enabled immediately when the output voltage exceeds 110% of its nominal. While the undervoltage latch protection will wait for a period of time set by the LDELAY capacitor. If the output voltage is still below 80% of its nominal after this waiting period, the latch protection will be enabled.

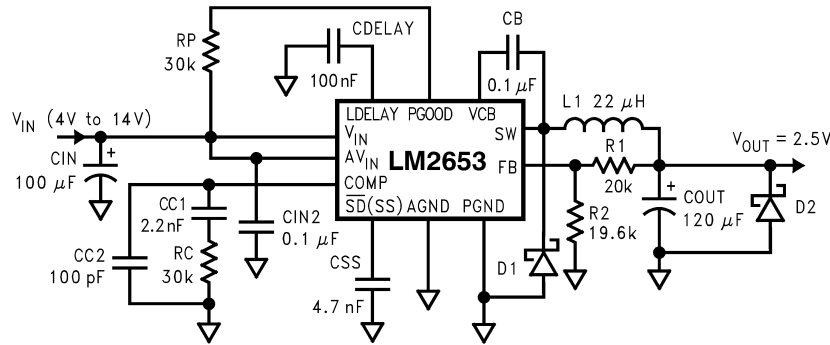

10113201

FIGURE 1. LM2653 EVAL Schematic

TABLE 1. Parts List (Bill Of Materials)

Designation	Description
L1	22μH, Coilcraft DO3316P-223
CIN (input capacitor)	100μF, 16V, Sprague 594D107X0016D2T
CIN2 (input capacitor)	0.1μF ceramic capacitor
CB (bootstrap capacitor)	0.1μF ceramic capacitor
CSS (softstart capacitor)	4.7nF ceramic capacitor
COUT (output capacitor)	120μF, 6.3V, Sprague 594D127X06R3C2T
CC1 (compensation)	2.2nF ceramic capacitor

Evaluation Board Design (Continued)

TABLE 1. Parts List (Bill Of Materials) (Continued)

Designation	Description
CC2 (compensation)	100pF ceramic capacitor
RC (compensation)	30kΩ, 5% resistor
D1	1A Schottky diode, Motorola MBRA130LT3
R1	20.0k, 1% resistor
R2	19.6k, 1% resistor
CDELAY	100nF ceramic capacitor
RP	50K, 5% resistor
D2	Open

Typical PC Board Layout: (2X Size)

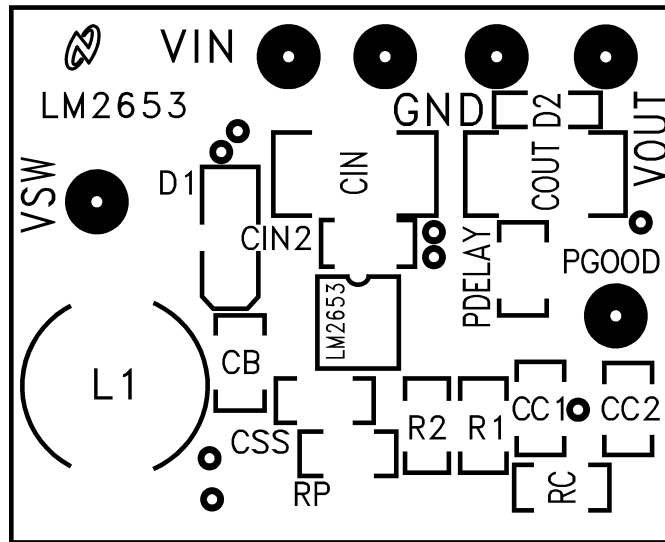

10113203

Component Placement Guide

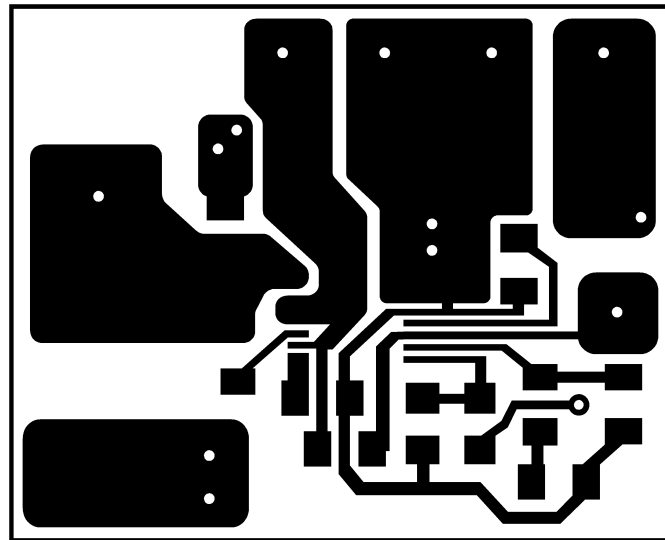

10113204

Component Side PC Board Layout

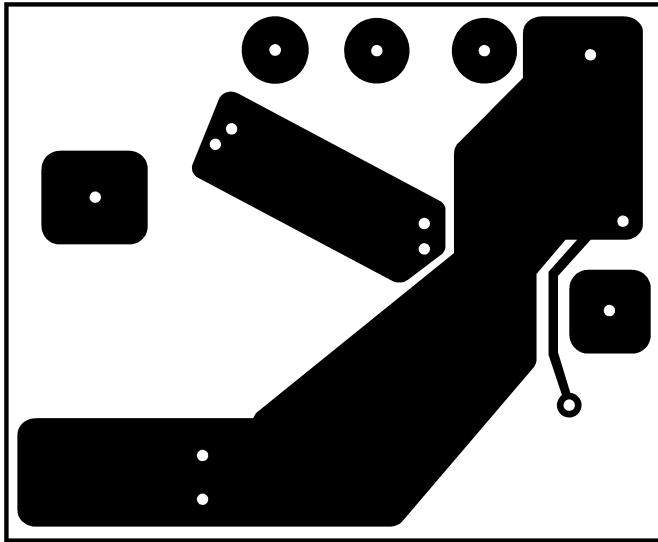
Typical PC Board Layout: (2X Size) (Continued)**Solder Side PC Board Layout**

10113205

LIFE SUPPORT POLICY

NATIONAL'S PRODUCTS ARE NOT AUTHORIZED FOR USE AS CRITICAL COMPONENTS IN LIFE SUPPORT DEVICES OR SYSTEMS WITHOUT THE EXPRESS WRITTEN APPROVAL OF THE PRESIDENT AND GENERAL COUNSEL OF NATIONAL SEMICONDUCTOR CORPORATION. As used herein:

1. Life support devices or systems are devices or systems which, (a) are intended for surgical implant into the body, or (b) support or sustain life, and whose failure to perform when properly used in accordance with instructions for use provided in the labeling, can be reasonably expected to result in a significant injury to the user.
2. A critical component is any component of a life support device or system whose failure to perform can be reasonably expected to cause the failure of the life support device or system, or to affect its safety or effectiveness.



National Semiconductor Corporation
Americas
Email: support@nsc.com

www.national.com

National Semiconductor Europe

Fax: +49 (0) 180-530 85 86
Email: europe.support@nsc.com
Deutsch Tel: +49 (0) 69 9508 6208
English Tel: +44 (0) 870 24 0 2171
Français Tel: +33 (0) 1 41 91 8790

National Semiconductor Asia Pacific Customer Response Group

Tel: 65-2544466
Fax: 65-2504466
Email: ap.support@nsc.com

National Semiconductor Japan Ltd.

Tel: 81-3-5639-7560
Fax: 81-3-5639-7507